

Timber Trim Through Plasterboard to Steel Framing

Applications

- Skirting
- Architraves
- Window frames

Countersunk Head (Extended Point)

Product Range			
Gauge	Dimensions	Pack Quantity	Part Number
6g	6-20x50mm	1000	6-311-0124-5
	6-20x65mm	500	6-311-0123-7

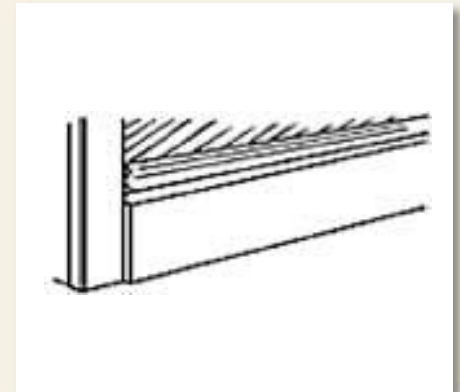

Metroll Newcastle
ABN 97 001 446 439
268 Macquarie Road
WARNERS BAY NSW 2282
AUSTRALIA

P: +61 (0)2 4954 5799
F: +61 (0)2 4954 0891
www.metrollnewcastle.com.au
enquiries@metrollnewcastle.com.au